

LED EMERGENCY DRIVER

Description:

The Espen Technology VEMB10W Emergency Lighting Inverter works with Espen's LED Flex (Type B) LED tubes in emergency system. The VEMB10W provides a maximum load of 10 Watts. It allows the connected fixture(s) to be on, off, switched or dimmed without affecting emergency operation. Each unit consists of electronic circuitry; lithium-ion battery and charger enclosed in a steel case.

Electrical:

- Universal 120-277V AC, 50/60Hz Input
- Open Circuit Voltage 200VDC
- Charge/Power "ON" LED Indicator Light and Push-to-Test Switch for Code Compliance Testing
- Long Life, Maintenance Free, Lithium-Ion Battery
- Output Short and Overcurrent Protection: Electronic Limiting, with Normal Operation Resuming
- 90 Minute Minimum Emergency Operating Time Over Full Temperature Range
- 24 Hour Maximum Battery Recharge Time

Installation:

- For Use with Switched or Un-Switched Fixtures
- Does Not Affect Normal Operation
- Emergency Driver and Lamps Must be Fed from Same Branch Circuit

Warranty:

- 5 years
- Meets UL924



Model: VEMB10W

Operates Espen Flex and Flex DE Type B LED 2ft, 3ft, 4ft T8 lamps, Flex DE 4ft T5HE and 4ft T5HO lamps

Technical Specifications

Input Voltage

120-277VAC

Lamp Operated

Espen Flex and Flex DE Type B LED 2ft, 3ft, 4ft T8 lamps, Flex DE 4ft T5HE and 4ft T5HO lamps

Emergency Operation

90 mins

Operating Temperature

0C/32F - 50C/120F

Battery

Lithium-Ion

Housing

Durable Steel Housing Contains LED Driver and Battery

Approval

Meets UL924

Case Dimensions:

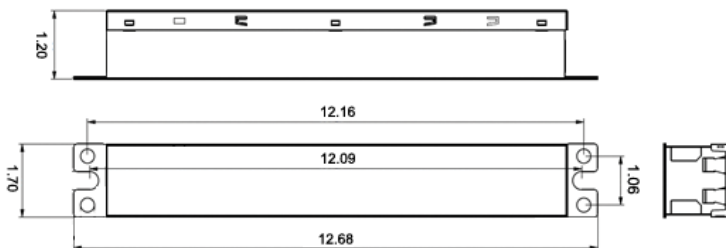

Wiring Diagram:

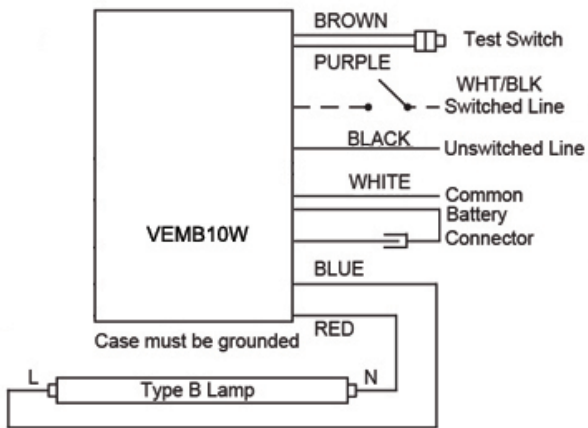

User Manual

[VEMB10W MANUAL.pdf](#)