

# RetroFlex LED Drivers for Type A LED Lamps

## VEL50BN-2C

### Constant Current



### Descriptions:

The RetroFlex LED drivers work direct with Type A LED lamps to turn it to a type C system. It replaces the outdated fluorescent ballast and maximize the efficiency of LED lamps. With exact same footprint and color coded leads, it is a simple one-to-one replacement. It is future-proof product to convert a fluorescent system fully to LED.

## VEL50BN-2C

### Features & Benefits:

- Universal Voltage (120-277V)
- Outdoor Type 1
- Constant Current
- Multi Channel Parallel Operation
- Integrates with Adaptive Lighting Control Systems
- Compatible with Type A LED Lamps
- UL, cUL, UL8750 Class 2
- FCC Part 15 Class A
- Operating Temperature: -22°F to 122°F
- Storage Temperature: -40°F to 131°F

**Specifications:**

Lamp Type	No of Lamps	Input Voltage	Input Power	Input Current (mA)	Power Factor	THD	Dimming	Min. Starting Temp (C)
L24T8/8XX/10G-EB	1	120-277V	15W	0.13@120V	>0.90	<10%	N/A	-18C
L24T8/8XX/10G-EB	2	120-277V	24W	0.2@120V	>0.90	<10%	N/A	-18C
L36T8/8XX/10G-EB	1	120-277V	15W	0.13@120V	>0.90	<10%	N/A	-18C
L36T8/8XX/10G-EB	2	120-277V	24W	0.2@120V	>0.90	<10%	N/A	-18C
L48T8/8XX/10G-EB	1	120-277V	16W	0.13@120V	>0.90	<10%	N/A	-18C
L48T8/8XX/10G-EB	2	120-277V	26W	0.22@120V	>0.90	<10%	N/A	-18C
L48T8/8XX/12G-EB	1	120-277V	17W	0.14@120V	>0.90	<10%	N/A	-18C
L48T8/8XX/12G-EB	2	120-277V	30W	0.25@120V	>0.90	<10%	N/A	-18C
L48T8/8XX/12G-EB-AC	1	120-277V	17W	0.14@120V	>0.90	<10%	N/A	-18C
L48T8/8XX/12G-EB-AC	2	120-277V	30W	0.25@120V	>0.90	<10%	N/A	-18C
L48T8/8XX/14G-EB	1	120-277V	18W	0.15@120V	>0.90	<10%	N/A	-18C
L48T8/8XX/14G-EB	2	120-277V	34W	0.28@120V	>0.90	<10%	N/A	-18C
L48T8/8XX/15G-EB-AC	1	120-277V	19W	0.16@120V	>0.90	<10%	N/A	-18C
L48T8/8XX/15G-EB-AC	2	120-277V	36W	0.3@120V	>0.90	<10%	N/A	-18C
L48T8/8XX/12P-EB	1	120-277V	17W	0.14@120V	>0.90	<10%	N/A	-18C
L48T8/8XX/12P-EB	2	120-277V	30W	0.25@120V	>0.90	<10%	N/A	-18C
L24T8/8XX/9G-AB	1	120-277V	15W	0.13@120V	>0.90	<10%	N/A	-18C
L24T8/8XX/9G-AB	2	120-277V	24W	0.2@120V	>0.90	<10%	N/A	-18C
L36T8/8XX/11G-AB	1	120-277V	16W	0.13@120V	>0.90	<10%	N/A	-18C
L36T8/8XX/11G-AB	2	120-277V	28W	0.23@120V	>0.90	<10%	N/A	-18C
L48T8/8XX/12G-AB	1	120-277V	17W	0.14@120V	>0.90	<10%	N/A	-18C
L48T8/8XX/12G-AB	2	120-277V	30W	0.25@120V	>0.90	<10%	N/A	-18C
LB31T8U/8XX/13P-AB	1	120-277V	18W	0.15@120V	>0.90	<10%	N/A	-18C
LB31T8U/8XX/13P-AB	2	120-277V	32W	0.27@120V	>0.90	<10%	N/A	-18C
LB48T8U6/8XX/13P-AB	1	120-277V	18W	0.15@120V	>0.90	<10%	N/A	-18C
LB48T8U6/8XX/13P-AB	2	120-277V	32W	0.27@120V	>0.90	<10%	N/A	-18C

**Dimensions:**

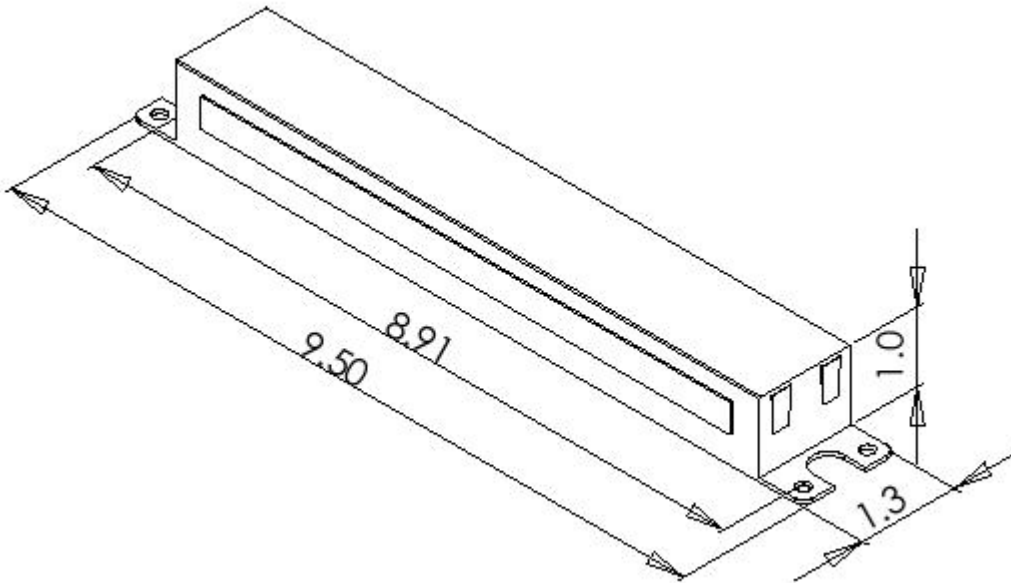

Ordering Code	Length (in)	Width (in)	Height (in)	Mounting (in)	Input Black Lead (in)	Input White Lead (in)	Output Red Lead (in)	Output Blue Lead (in)	Output Yellow Lead (in)
VEL50BN-2C	9.5	1.3	1.1	8.9	22	22	46	31	N/A

**Wiring Diagram:**

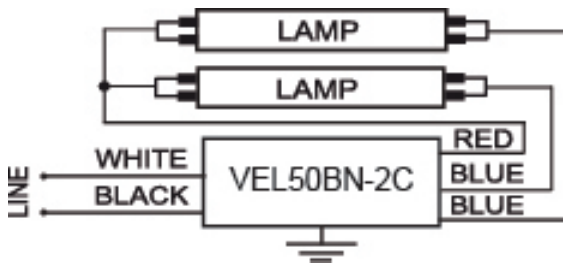

Specification data is based on tests performed in a controlled environment and represents relative performance. Actual performance can vary depending on operating conditions. Application and performance data subject to change without notice. All specifications are nominal unless noted otherwise.