

BAA/TAA Compliant LED Troffer Retrofit Kit with 3 Level Power 2X2

APPLICATIONS

This advanced troffer retrofit kit easily converts 2X2 fluorescent troffers to the most current LED technology. Its ultra high efficiency reduces energy costs. It is one of the LED troffer retrofits that comes completely assembled as a lensed kit, requiring only one minute to install, reducing labor costs. The retrofit kit is also 0-10V Dimmable with 5 Year Warranty. Ideal applications include: office, retail, healthcare, education and hospitality interiors.

PERFORMANCE

The VEK series uses the latest LED technology and LED driver to ensure steady performance and long lifetime.

INSTALLATION

The Troffer Retrofit Kit provides the ideal way to replace existing 2X2 recessed troffer, utilizing the existing fixture housing. The kit provides all the components needed to perform the change out quickly and efficiently, allowing for system upgrades without disturbing the ceiling. The LED troffer retrofit is completely assembled within the frame. With special 2-in-1 design, the kit fits for both air return troffers and standard troffers.

[*Emergency Driver Solution Option](#)



Specification Data

Model No.	Watts (W)	Lumens (lm)	CCT	Efficacy (lm/W)	Input Voltage (Vac)	Dimming	Life (L70) hours	THD	CRI	Power Factor
VEKT2X2-8T (20W/25W/30W) BAA	20/25/30	2500/3125/3750	3500/4000/5000	125	120-277	0-10V	>100,000	<20%	>80	0.9

Dimensions

Length	Width	Height
1.78 ft	1.85 ft	2.76 in

Wiring Diagram

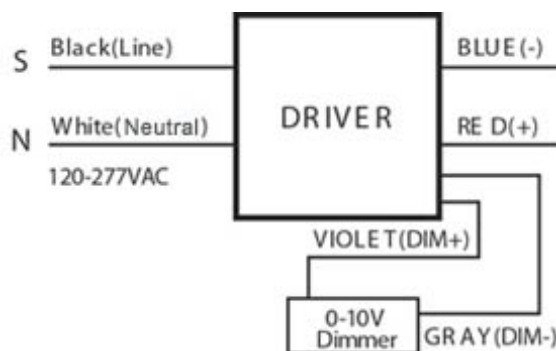

DLC Information

Order Code	DLC Product ID	DLC Product Model	DLC Version
VEKT2X2-8T (20W/25W/30W) BAA	P9X6SKH0	VEKT2X2/8T (20W/25W/30W)	5.1