

Slimline

L96T8/8XX/24G-EB

Commercial Grade LED T8 Lamp

Descriptions:

The RetroFlex (Type A) LED lamps provide hassle-free installation with simple lamp-for-lamp replacements for your linear fluorescent T8 or T12 slimline (FA8) retrofit needs. Fully certified to replace original fluorescent lamps, these lamps provide the perfect, hassle-free solution for whatever the project requires. When being used with an instant start, programmed start, or emergency backup ballast, no fixture re-wiring is needed.



Features & Benefits:

- No rewiring needed
- Works with fluorescent electronic ballast [VE259MVHIP](#)
- Long life
- High CRI
- Instant on, no delay
- Convenient and quick installation
- Utilizes existing instant start or rapid start sockets
- Compatible with controls and sensors
- No Mercury, No UV
- Works in cold temperature applications
- Glass tube for superior optical performance
- Wide View Angle
- 5 Year Warranty
- New Version with Integrated ArmorCoat For use in food areas and refrigerated food displayers

Specifications (Based on Normal Ballast Factor):

Ordering Code	Length (in)	Lamp Wattage	System Wattage	CCT (K)	Initial Lumens	CRI	Beam Angle	Lamp Efficacy	System Efficacy	Life (hr)
L96T8/835/24G-EB	96	24	27	3500K	3500	83+	325	135	120	50,000
L96T8/840/24G-EB	96	24	27	4000K	3500	83+	325	135	120	50,000
L96T8/850/24G-EB	96	24	27	5000K	3500	83+	325	135	120	50,000

Wiring Diagram:

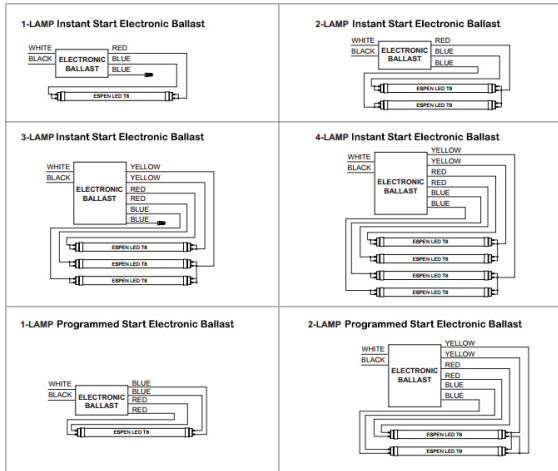

- Please refer to "Ballast Compatibility List" for compatible battery backup and/or emergency ballasts.
- Please refer to "Ballast Compatibility List" on Related Downloads.

Specification data is based on tests performed in a controlled environment and represents relative performance. Actual performance can vary depending on operating conditions. Application and performance data subject to change without notice. All specifications are nominal unless noted otherwise.