

RetroFlex (Type A)

Commercial Grade LED T8 Lamp



RetroFlex™
LED T8 LAMP • Simplicity.

Features & Benefits

- Assembled in USA
- Shatterproof Nano Plastic Tube
- NSF2 Rated
- No rewiring needed
- Works with fluorescent electronic ballast (Instant Start, Programmed Start, and Dimming)*
- Long life
- High CRI
- Instant on, no delay
- Convenient and quick installation
- Utilizes existing instant start or rapid start sockets
- Compatible with controls and sensors
- Dimmable
- Works in cold temperature applications
- Super wide view angle
- 5 Year Warranty
- High performance plastic series



Specification

Order Code	Length	Lamp Wattage	System Wattage	CCT	Initial Lumens	CRI	Beam Angle	Lamp Efficacy	System Efficacy	Life
L36T8/835/12P-EB BAA/TAA	36	12	14	3500K	1700	83	325	135	120	50000
L36T8/840/12P-EB BAA/TAA	36	12	14	4000K	1700	83	325	135	120	50000
L36T8/850/12P-EB BAA/TAA	36	12	14	5000K	1700	83	325	135	120	50000

System Performance

Lamp Model	Low Ballast Factor				High Ballast Factor			
	Lamp Power	System Power	Lumen Output	Lamp Efficacy	Lamp Power	System Power	Lumen Output	Lamp Efficacy
L36T8/835/12P-EB BAA/TAA								
L36T8/840/12P-EB BAA/TAA								
L36T8/850/12P-EB BAA/TAA								

Wiring Diagram

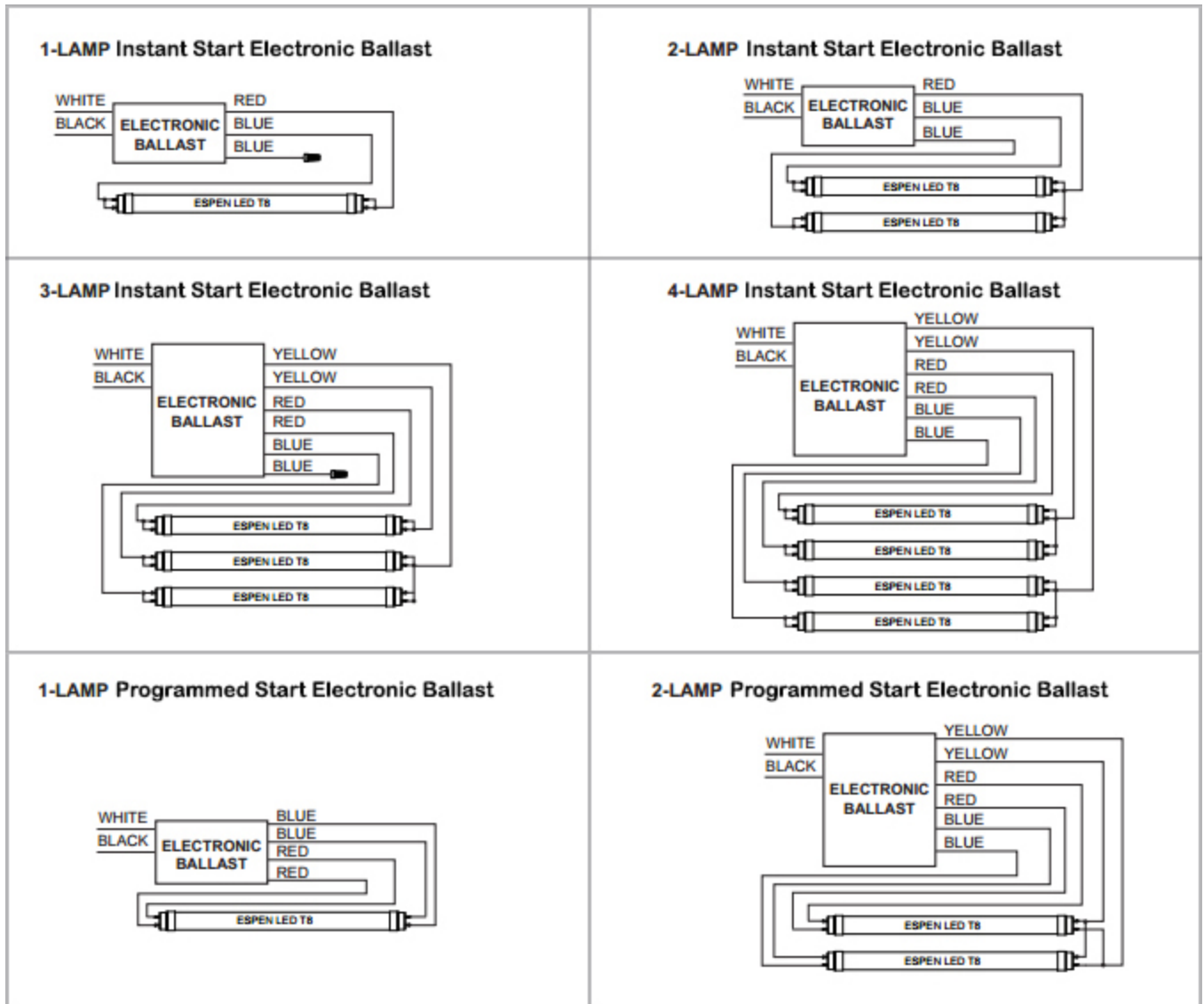

Dlc Information

Order Code	DLC Product ID	DLC Product Model	DLC Version
L36T8/835/12P-EB BAA/TAA	PKMIEMK9	L36T8/835/12P-EB	5
L36T8/840/12P-EB BAA/TAA	P8UVZZQX	L36T8/840/12P-EB	5
L36T8/850/12P-EB BAA/TAA	P6E6AP75	L36T8/850/12P-EB	5

* Please refer to "Ballast Compatibility List" for compatible battery backup and/or emergency ballasts.

* Please refer to "Ballast Compatibility List" on Related Downloads.

Specification data is based on tests performed in a controlled environment and represents relative performance. Actual performance can vary depending on operating conditions. Application and performance data subject to change without notice. All specifications are nominal unless noted otherwise.